









| HARDWARE LIST | | | |
|---------------|---|-----------------|------|
| NO. | PART | DESCRIPTION | Q'TY |
| A |  | glass top | 1 |
| B |  | leg | 4 |
| C |  | metal part | 1 |
| D |  | rod | 4 |
| E |  | screw | 4 |
| F |  | caps | 8 |
| G |  | screw nut | 4 |
| H |  | hexagon spanner | 1 |
| I |  | allen key | 1 |



step 1

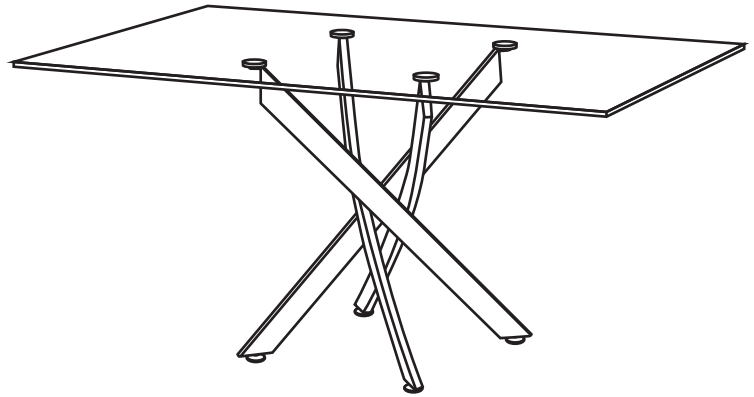
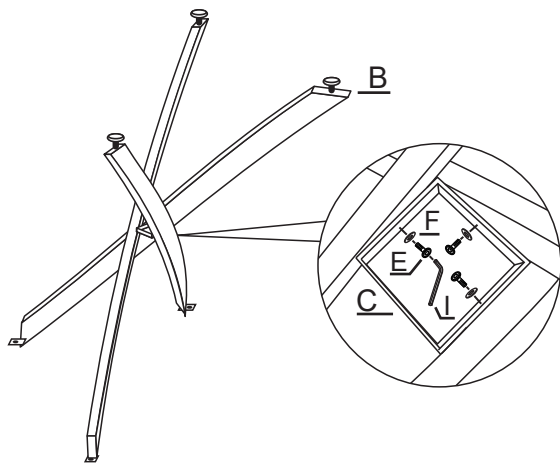

step 2

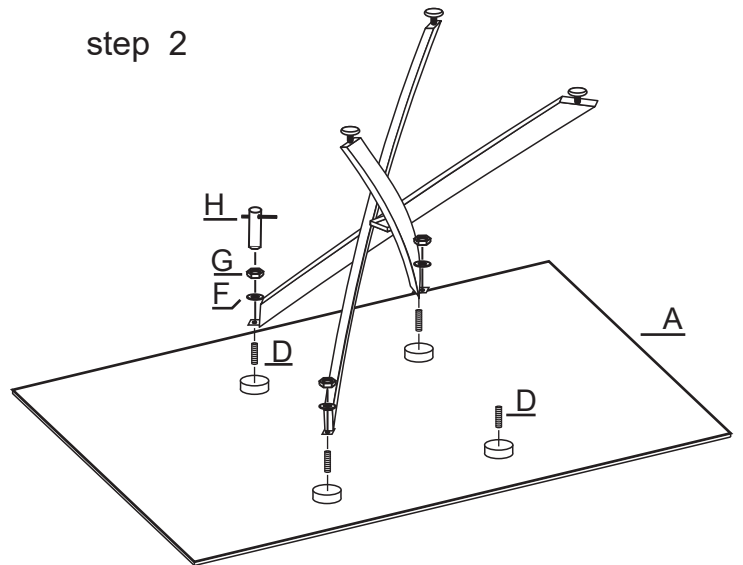

step 3

step 4

