









HARDWARE LIST			
NO.	PART	DESCRIPTION	Q'TY
A		glass top	1
B		leg	4
C		metal part	1
D		rod	4
E		screw	4
F		caps	8
G		screw nut	4
H		hexagon spanner	1
I		allen key	1



step 1

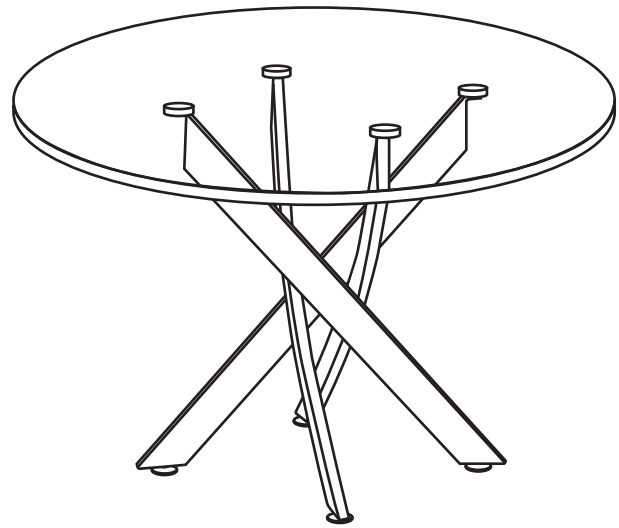
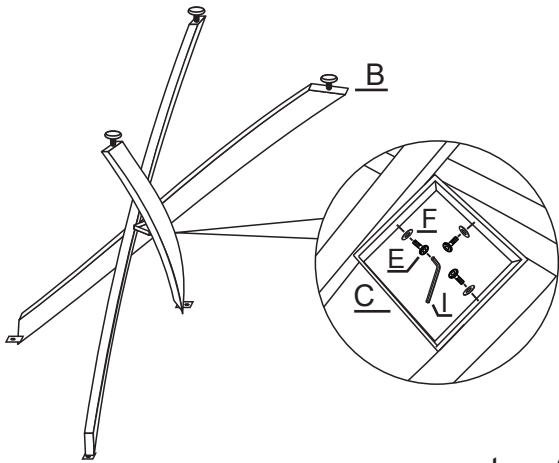

step 2

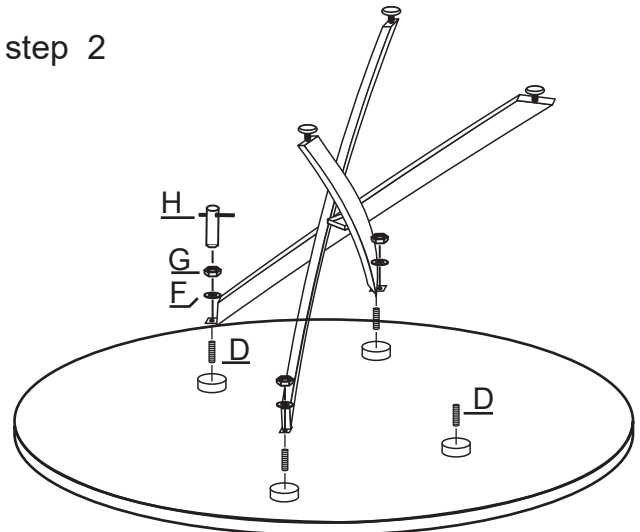

step 3

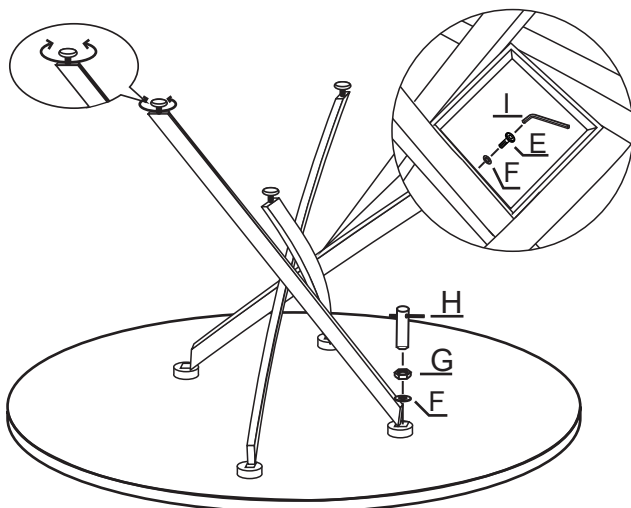

step 4

