

Outillage nécessaire

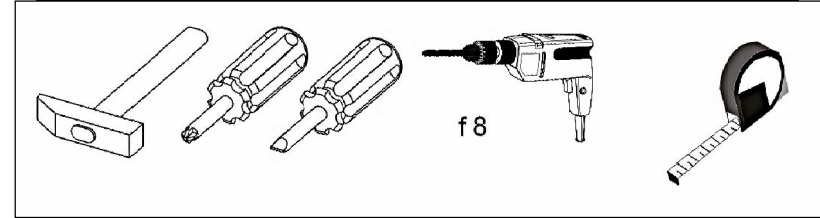

Principe d'assemblage pas goujon/excentrique

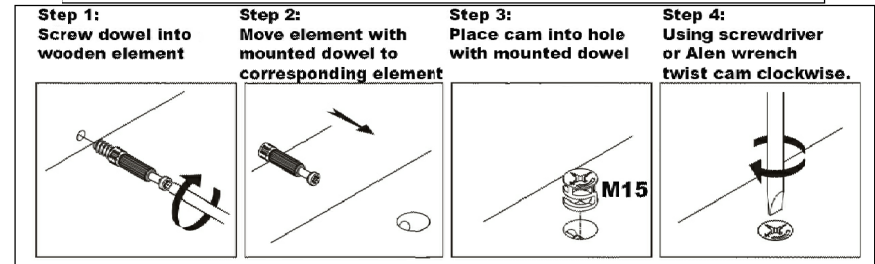

Instructions d'assemblage

Fig. 1-4.

Assemblage des éléments.

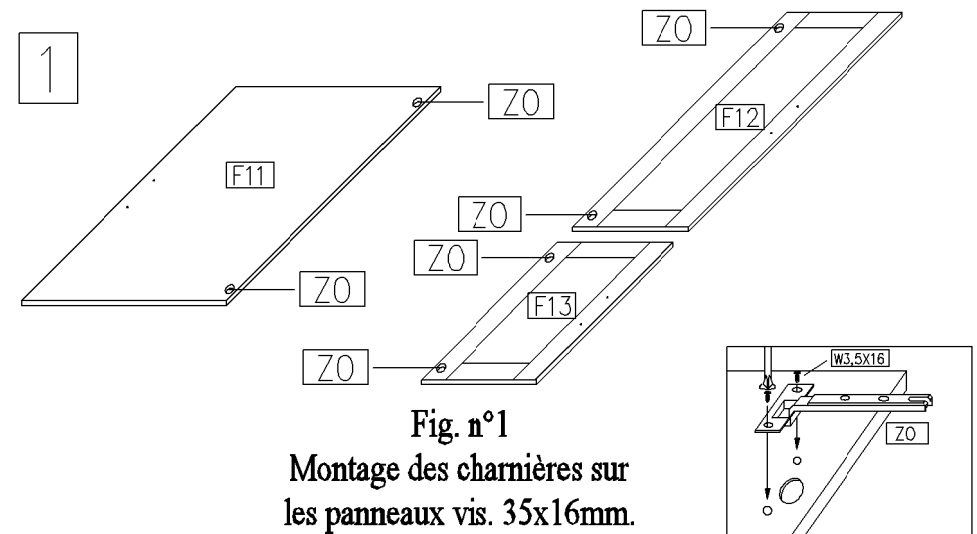

2

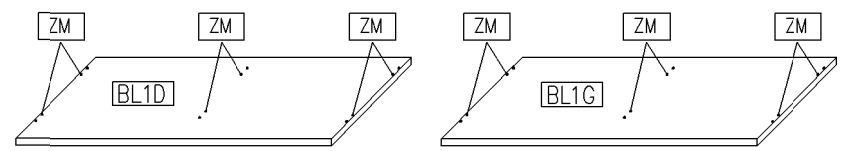
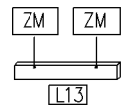
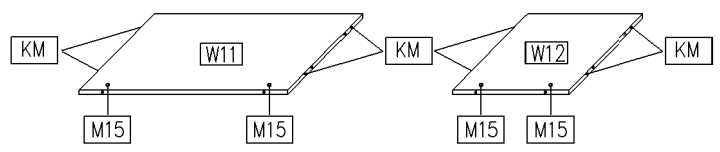
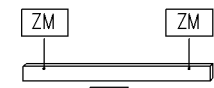
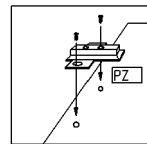
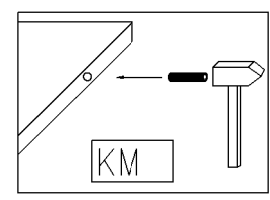
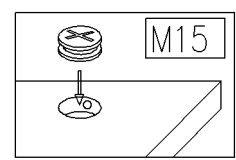
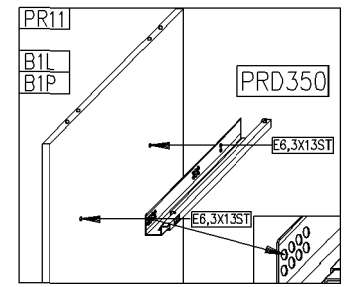
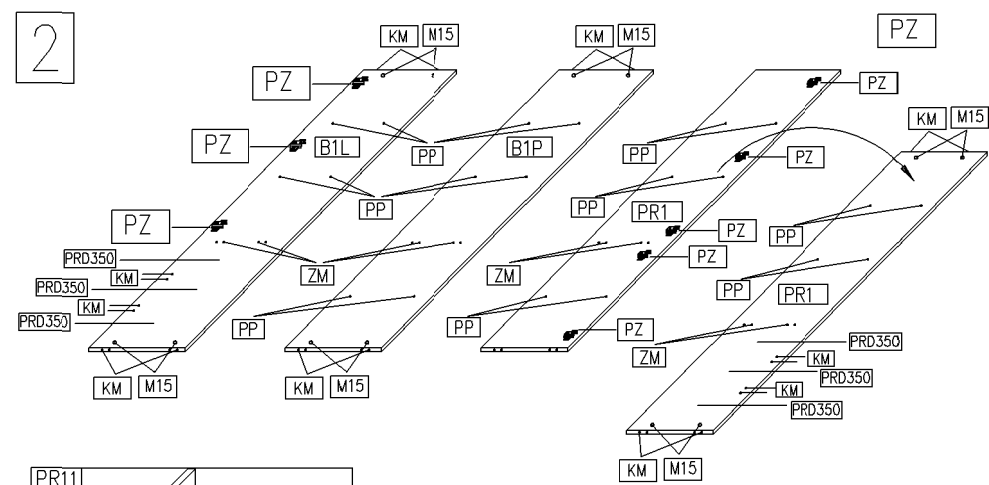

3

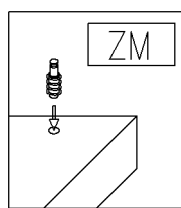
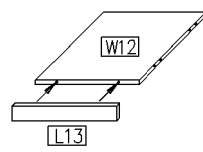
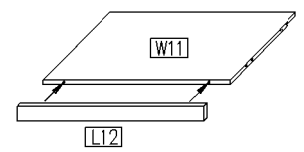

4

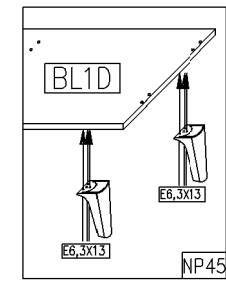
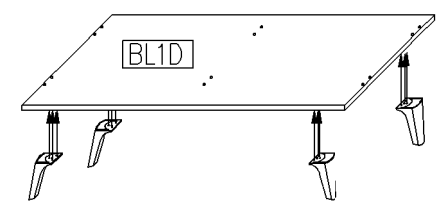

5

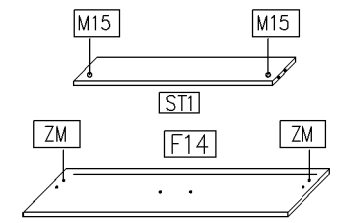
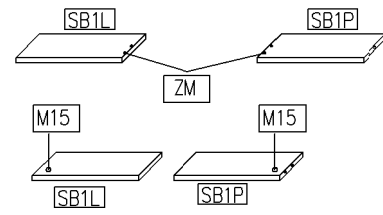

6

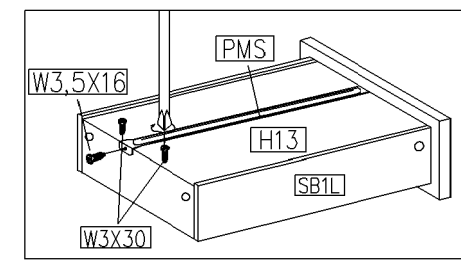
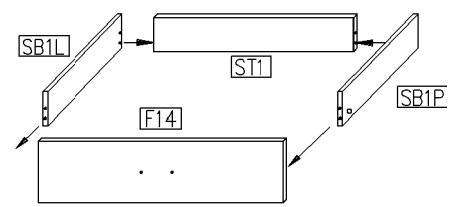

7

Monter l'ensemble sur le socle W11,W12 (M15/ZM/KM)

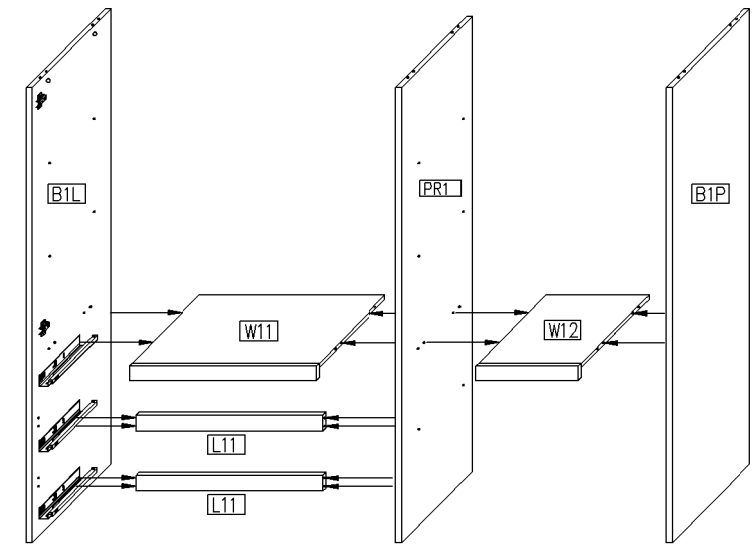

8

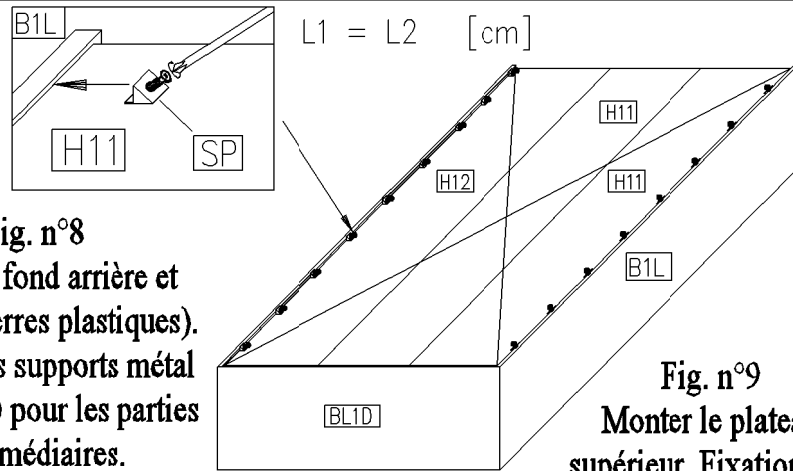

Fig. n°8
Placer le fond arrière et
fixer (équerres plastiques).
Utiliser les supports métal
et vis 3x20 pour les parties
intermédiaires.

9

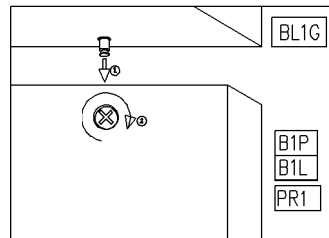

Fig. n° 10
Insérer ensuite les étagères.

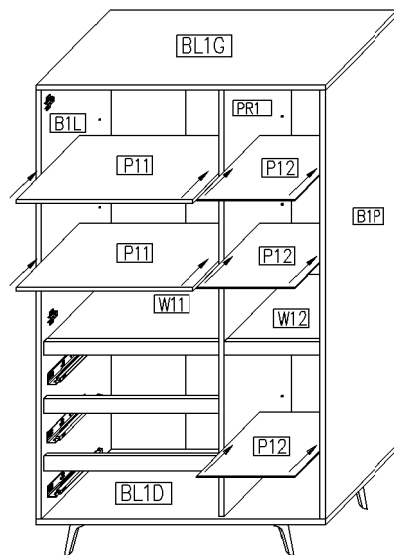
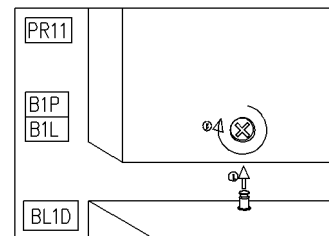
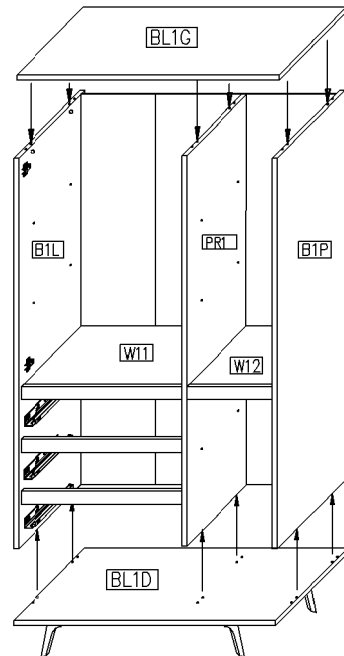

Fig. n°9
Monter le plateau
supérieur. Fixation par
goujon/excentrique.



11

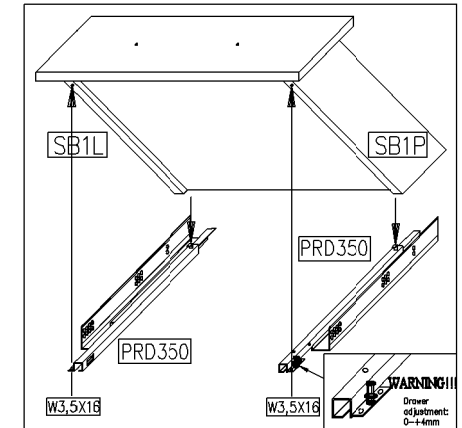
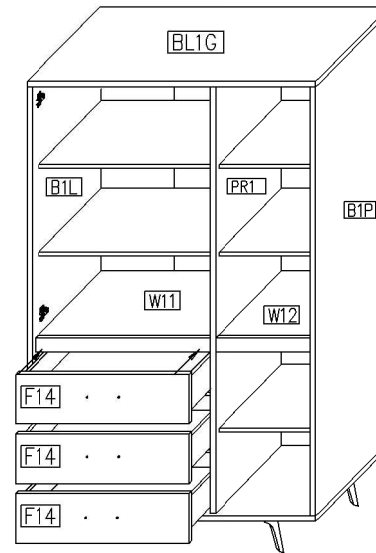

Fig. n°12
Monter ensuite les portes pour finaliser l'assemblage.
Vérifier l'alignement et rectifier si besoin.

12

