

Outillage nécessaire

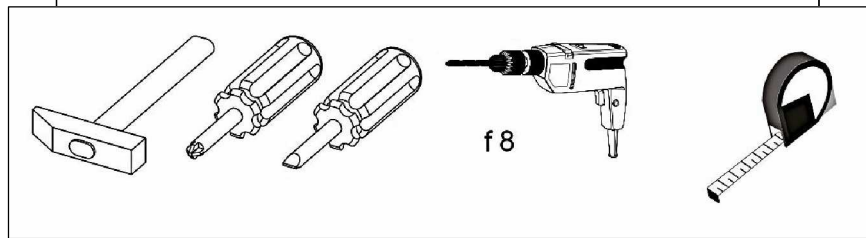

Principe d'assemblage par goujon/excentrique

<p><b>Step 1:</b> Screw dowel into wooden element</p>	<p><b>Step 2:</b> Move element with mounted dowel to corresponding element</p>	<p><b>Step 3:</b> Place cam into hole with mounted dowel</p>	<p><b>Step 4:</b> Using screwdriver or Allen wrench twist cam clockwise.</p>
---	--	--	--

ATTENTION! Avant l'installation, examiner soigneusement les étapes d'assemblage fournies par le fabricant.

Fig. 1-3

Préparation des éléments avant assemblage

1

2

3

Fig. n°3

Assemblage des pieds NL11/NL12/NL13/NL14 (vis goujon/excentrique)

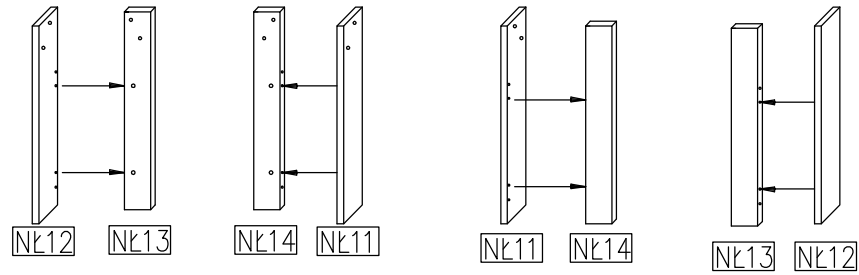

4

Fig. n°4

Assemblage des traverses de soutien du plateau supérieur par vis goujon/excentrique

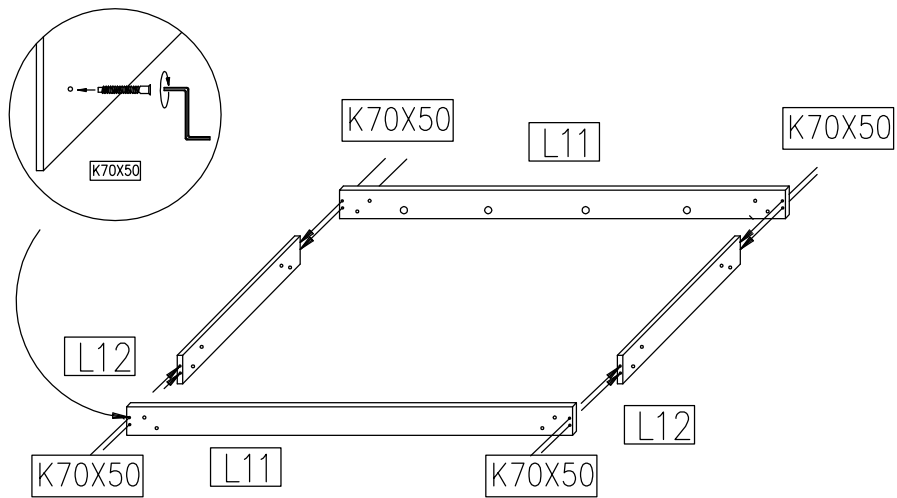

5

Fig. n°5

Assemblage du plateau inférieur et finaliser le montage.

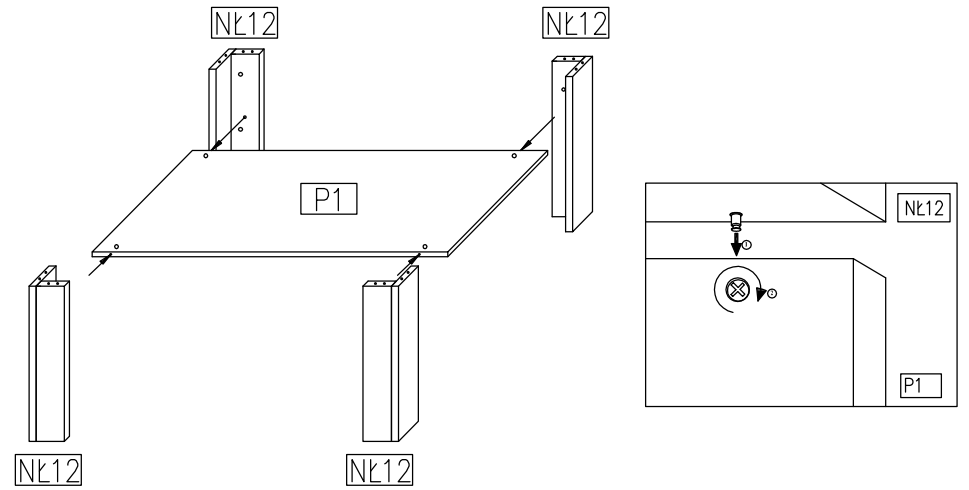

6

Fig. 6

Rassembler les pieds sur les traverses.

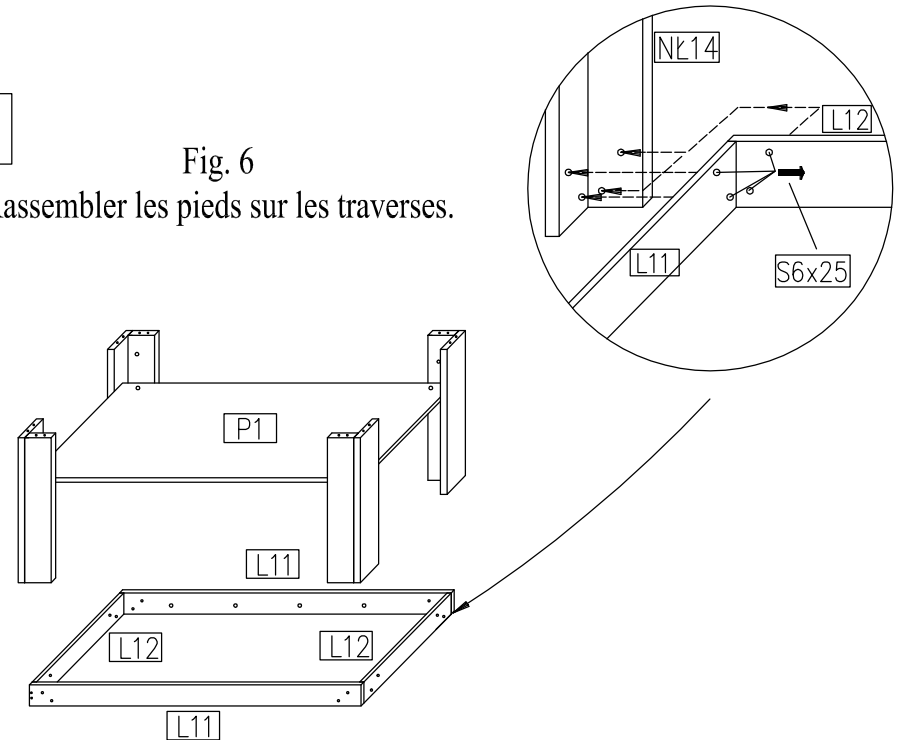

7

Fig. n°7  
Monter l'ensemble sur le  
plateau supérieur.

