

"WIVA" "WIK-1"

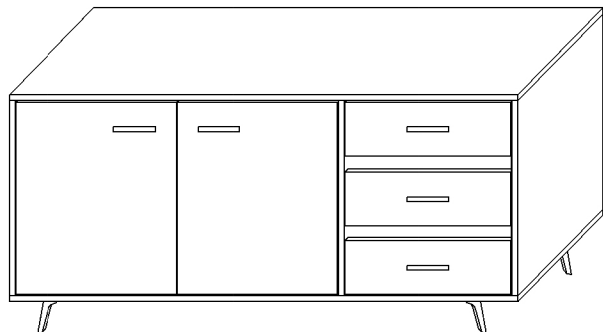

NOTICE DE MONTAGE A CONSULTER AVANT TOUTE OPERATION D'ASSEMBLAGE
Merci de vérifier la bonne conformité des pièces ainsi que la quantité.
En cas d'éléments manquants ou endommagés, veuillez nous contacter le plus rapidement possible.

L'opération d'assemblage est à effectuer sur une surface propre et sec (couverture). Les dommages causés par un montage incorrect et le non-respect de la séquence d'assemblage ne peut faire l'objet de contestation.

Dans le cas où l'une des chevilles en bois qui sortait du trou sur une longueur supérieure à 10 mm ne devrait pas être utilisée, elle peut causer des dommages aux meubles en passant au travers.
Ce cas ne peut ne peut être soumis à une contestation.

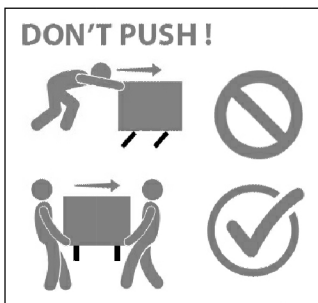

Eléments contenus dans le paquet

Eléments d'assemblage			Quincaillerie		
H11	Fond arrière	2 szt.	KM	Cheville en bois	36 szt.
B1L	Panneau montant gauche	1 szt.	KF	Clé montage	1 szt.
B1P	Panneau montant gauche	1 szt.	M15	Esc. entrrique	40 szt.
BL1G	Platneau supérieur	1 szt.	ZM	Goujon	40 szt.
BL1D	Soche inférieur	1 szt.	ZMU	Capuchon	40 szt.
PR11	Panneau séparation	1 szt.	W3X30	Vis 3x30	9 szt.
PR12	Panneau séparation	1 szt.	W3X20	Vis 3x20	8 szt.
F11	Portes	1 szt.	PP	Tapet	8 szt.
F12	Portes	1 szt.	W3,5X16	Vis 3,5x16	14 szt.
P1	Etagère	2 szt.	E63X13	Vis 6,3x13	12 szt.
L1	Elément panneau	2 szt.	U-UR	Poignée UR	8 szt.
F13	Facade tiroir	3 szt.	W4X27P	Vis poignée 4x27	16 szt.
ST1	Panneau arrière tiroir	3 szt.	PRD350	Glissière tiroir	3 szt.
SB1L	Côté gauche tiroir	3 szt.	E63X13ST	Vis conique	12 szt.
SB1P	Côté droit tiroir	3 szt.	SP	Equerre	30 szt.
H12	Fond tiroir	3 szt.	ZO	Elément charnière	4 szt.
			PZ	Elément charnière	4 szt.
			NP45	Support en plastique	6 szt.
			E63X13	Vis pour NP45	18 szt.
			PMS	Renfort fond de tiroir	3 szt.

PRD350

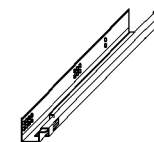

PMS		PZ	ZO		KM		ZM
SP	W4X35P	W4X30PPP			K70X50		M15
ZK	ZMU	UPR02		KF	NP45	W35X16	W3X30
						W4X30	W4X20

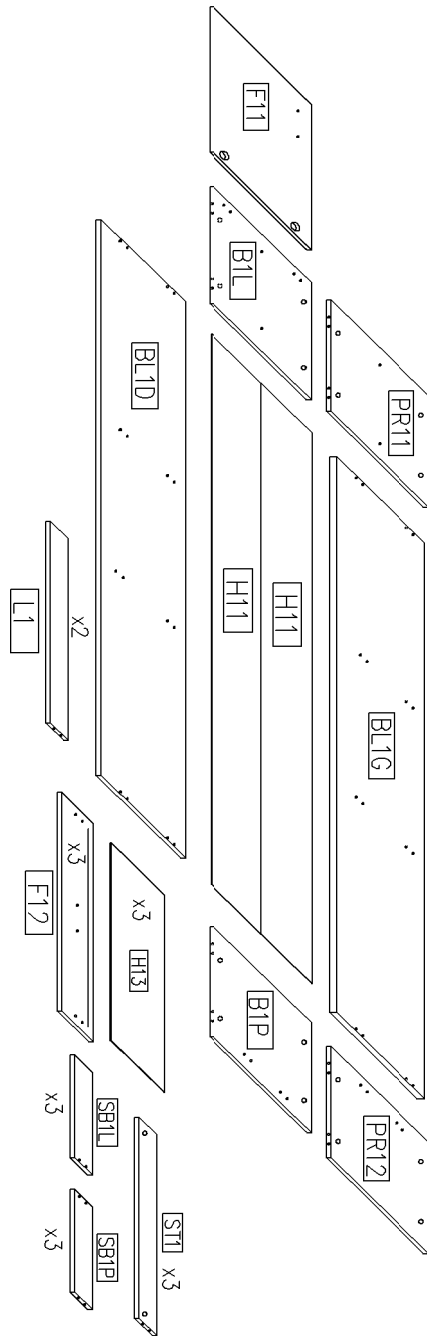

Outillage nécessaire

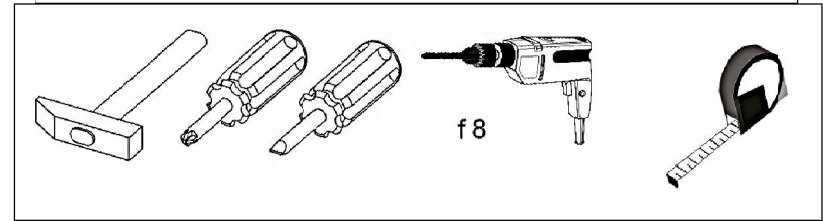

Principe d'assemblage pas goujon/excentrique

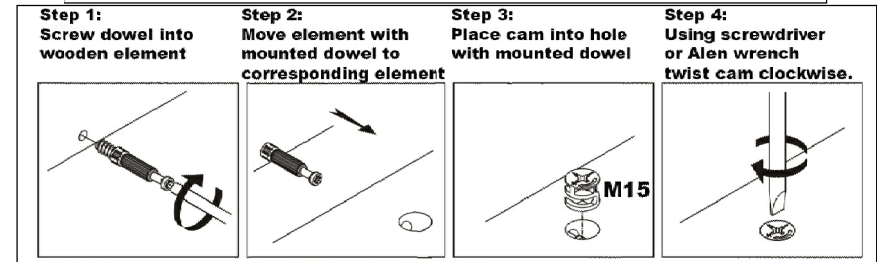

Instructions d'assemblage

Fig 1-4.

Assemblage des éléments.

1

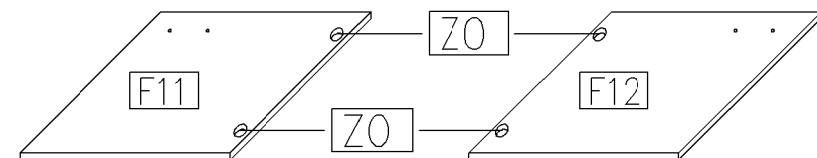
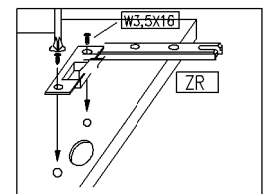
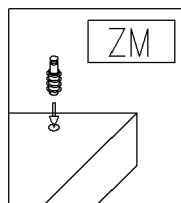
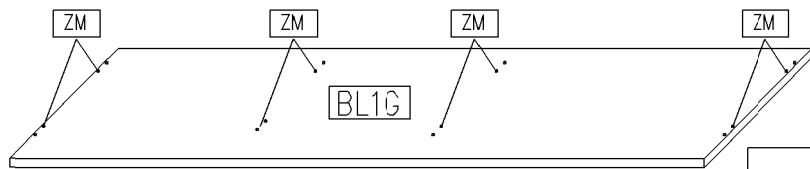
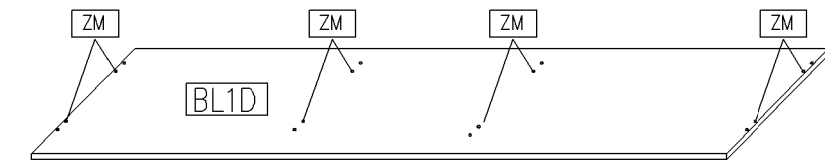
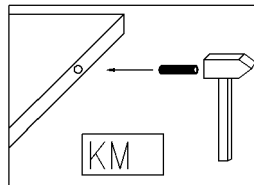
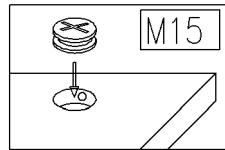
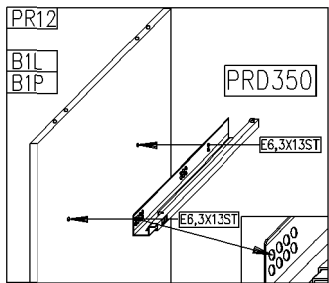
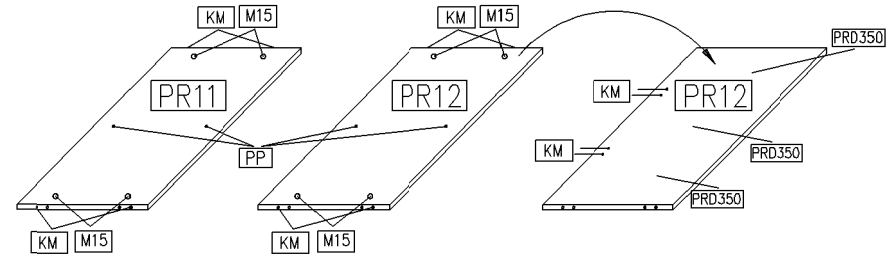
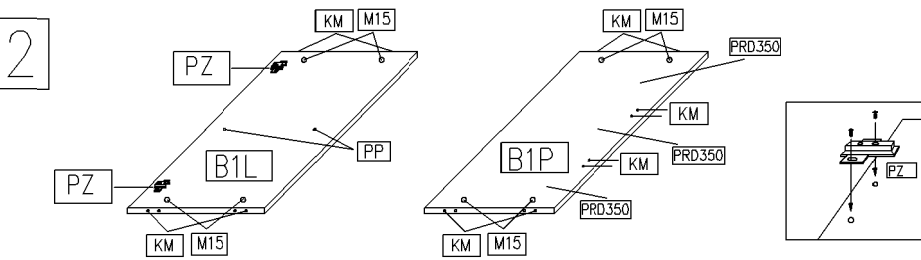

Fig. n°1

Montage des charnières sur les panneaux vis. 35x16mm.



2



3

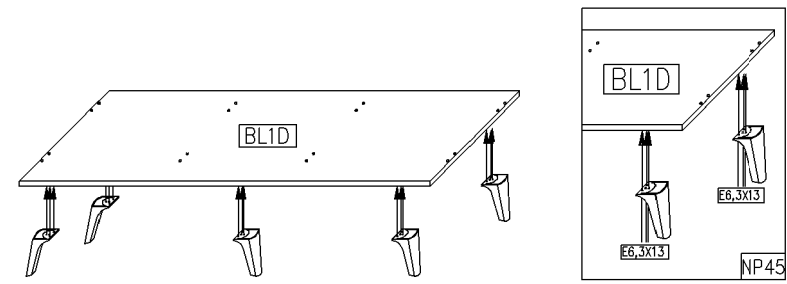

4

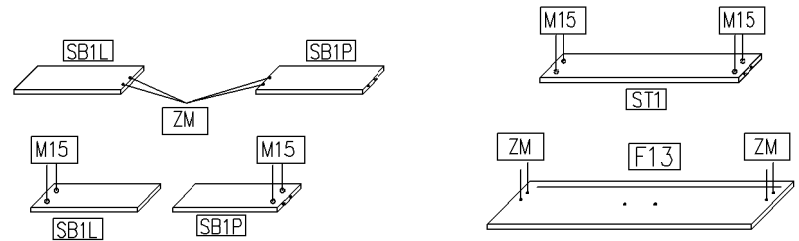

5

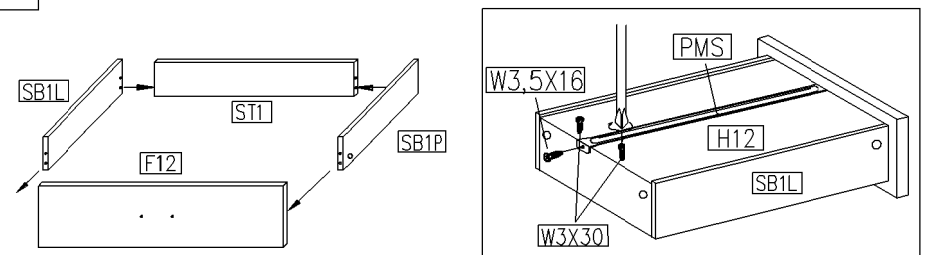

6

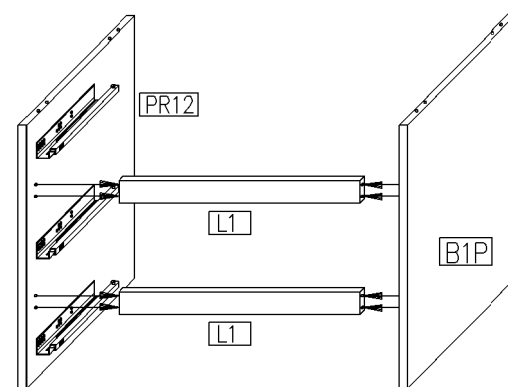

7

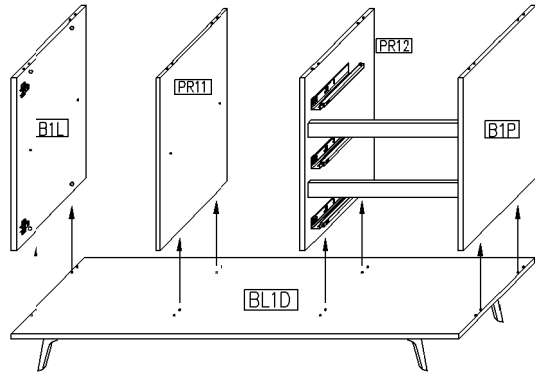
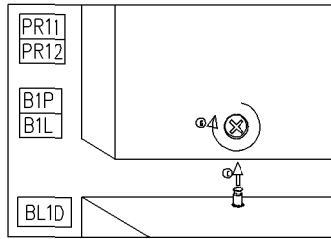

8

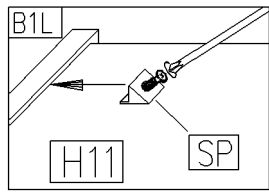

Rys. 8
Montujemy pilśnie H11 za pomocą stabilizatora SP.

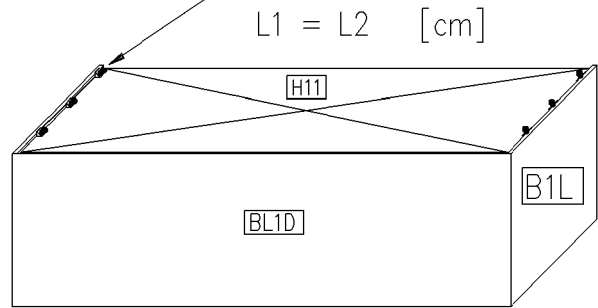

9

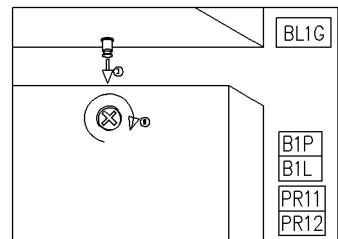
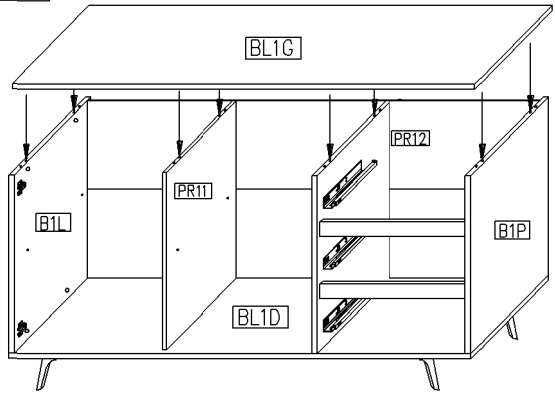

10

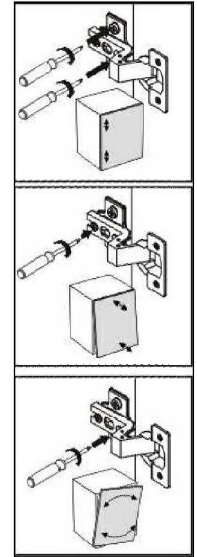
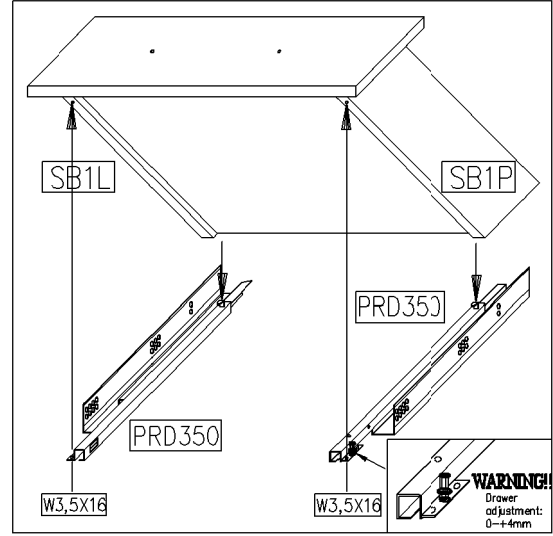
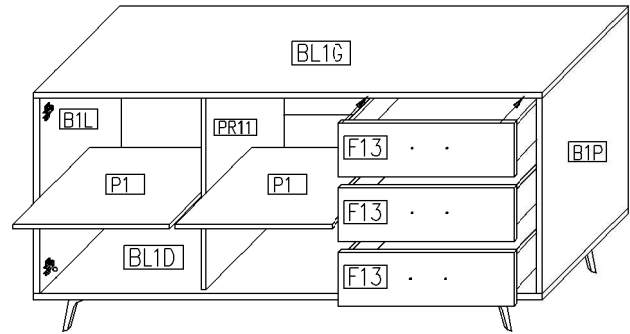

11

