

LEXUS

S20,S30,S35,S40,S45,S50

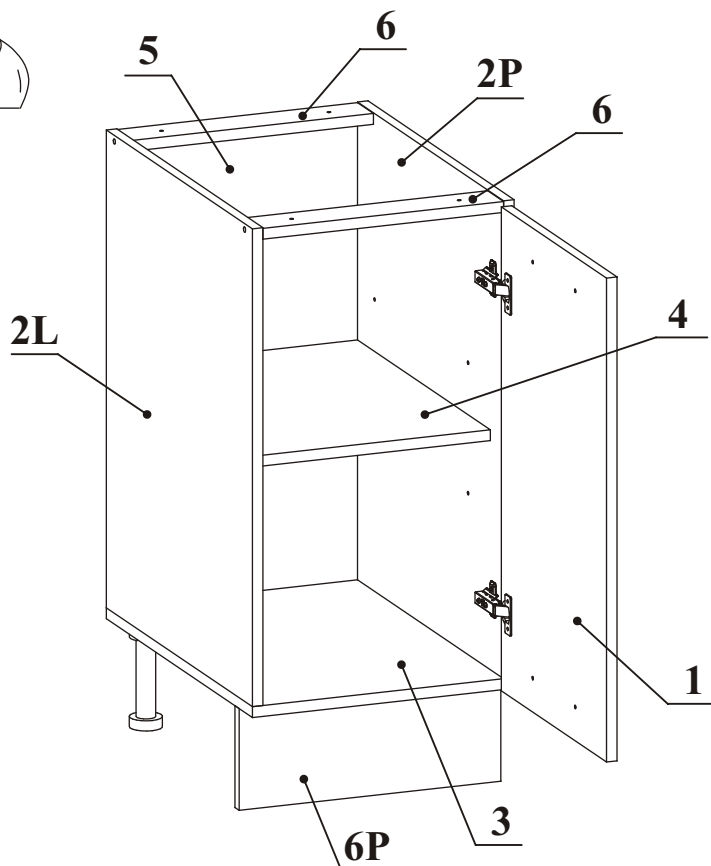

!!! KALA

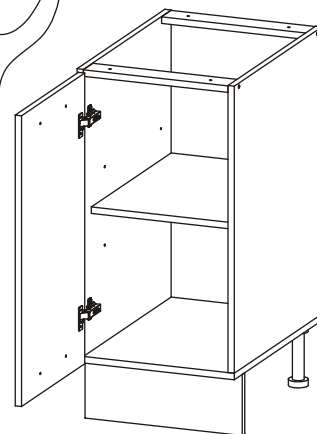
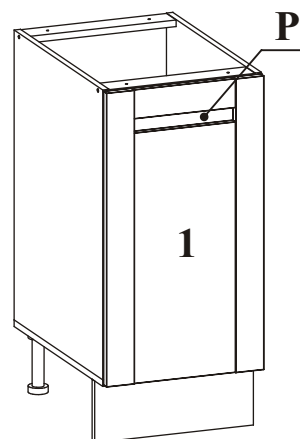

S20

NO	Dim.		Col.-No	Qty
2L	704	550	1	1
2P	704	550	1	1
3	200	550	1	1
4	168	500	1	1
5	715	197	1	1
6	168	60	1	2
6P	200	150	1	1
1	196	713	2	1

S30

NO	Dim.		Col.-No	Qty
2L	704	550	1	1
2P	704	550	1	1
3	300	550	1	1
4	268	500	1	1
5	715	297	1	1
6	268	60	1	2
6P	300	150	1	1
1	296	713	2	1

S35

NO	Dim.		Col.-No	Qty
2L	704	550	1	1
2P	704	550	1	1
3	350	550	1	1
4	318	500	1	1
5	715	347	1	1
6	318	60	1	2
6P	350	150	1	1
1	346	713	2	1

S40

NO	Dim.		Col.-No	Qty
2L	704	550	1	1
2P	704	550	1	1
3	400	550	1	1
4	368	500	1	1
5	715	397	1	1
6	368	60	1	2
6P	400	150	1	1
1	396	713	2	1

S45

NO	Dim.		Col.-No	Qty
2L	704	550	1	1
2P	704	550	1	1
3	450	550	1	1
4	418	500	1	1
5	715	447	1	1
6	418	60	1	2
6P	450	150	1	1
1	446	713	2	1

S50

NO	Dim.		Col.-No	Qty
2L	704	550	1	1
2P	704	550	1	1
3	500	550	1	1
4	468	500	1	1
5	715	497	1	1
6	468	60	1	2
6P	500	150	1	1
1	496	713	2	1



60 min

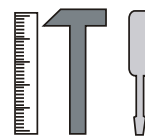
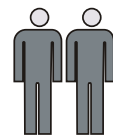

LEXUS S20,S30,S35,S40,S45,S50

E7 X2		E8 X2		B11 X10	 Ø7x50	G4 X10		D10 X4	 USØ3,5x13	D30 X20	 USØ3,5x16	
I13 X4	 L-150 mm.	I14 X2		UP6 X4	 UPØ4x30	Z2 X16	 Ø5	G7 X4		G2 X1		
* X1	 L-160mm !!! KALA; ZOBAL=0	G3 X2	 Ø35 KALA, ZOBAL X2	G9 X6	 KALA -COLI 2	D7 X6	 USØ3x16 KALA -COLI 2				UP13 X20	 UPØ3x16 S20-x16 S30-x17 S35-x18 S40-x19 S45-x20 S50-x21

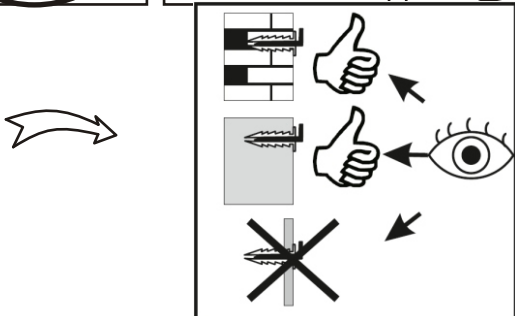
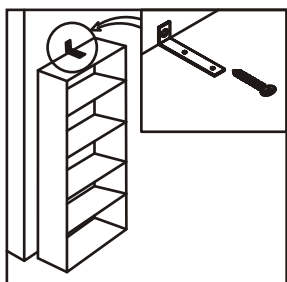
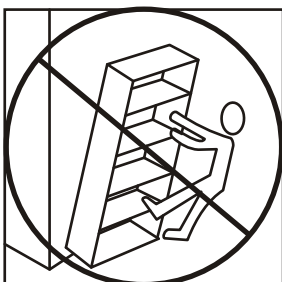
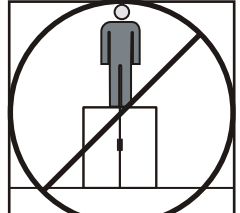
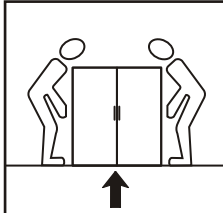
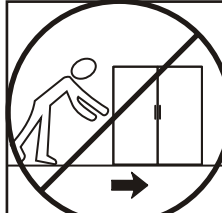
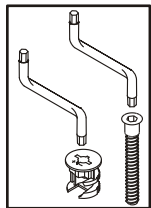
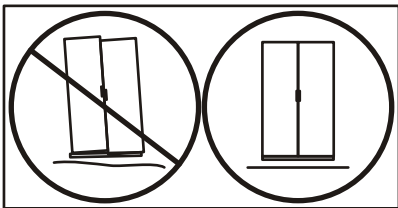
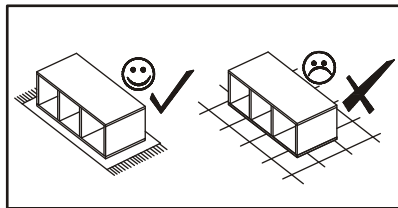
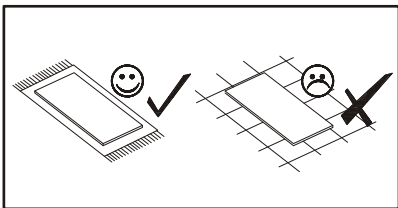
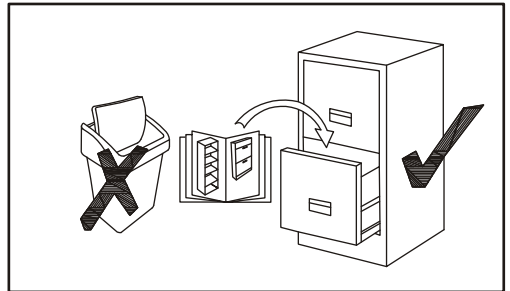
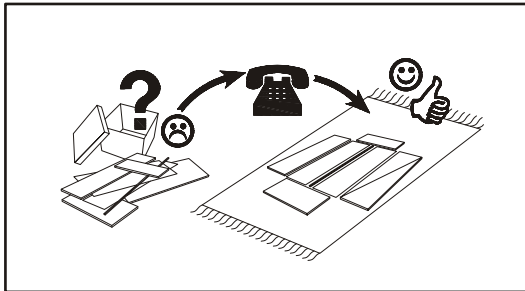
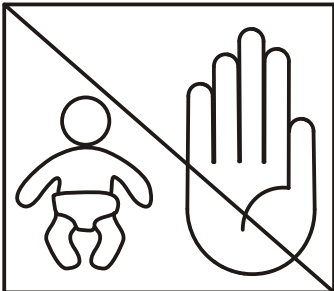
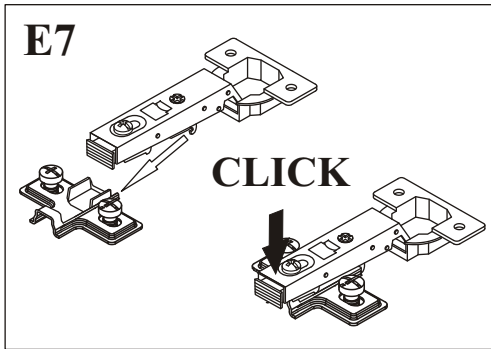
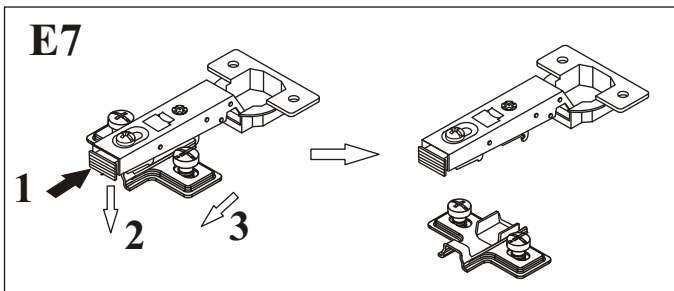
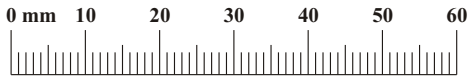

1

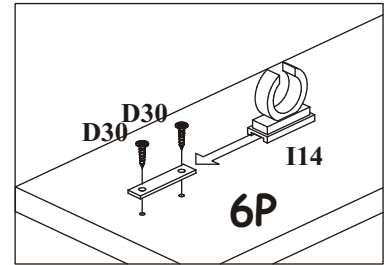
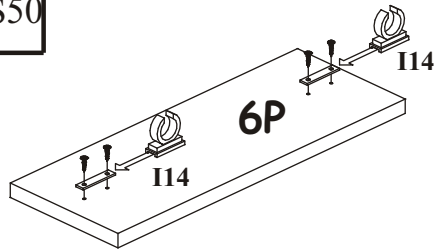

2

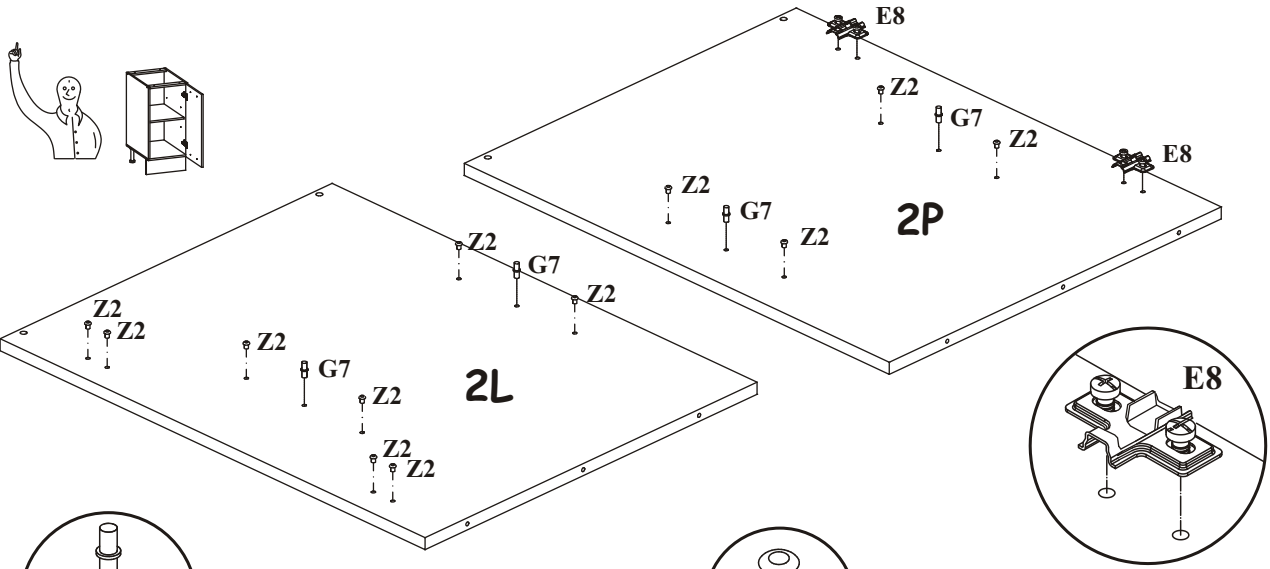

2

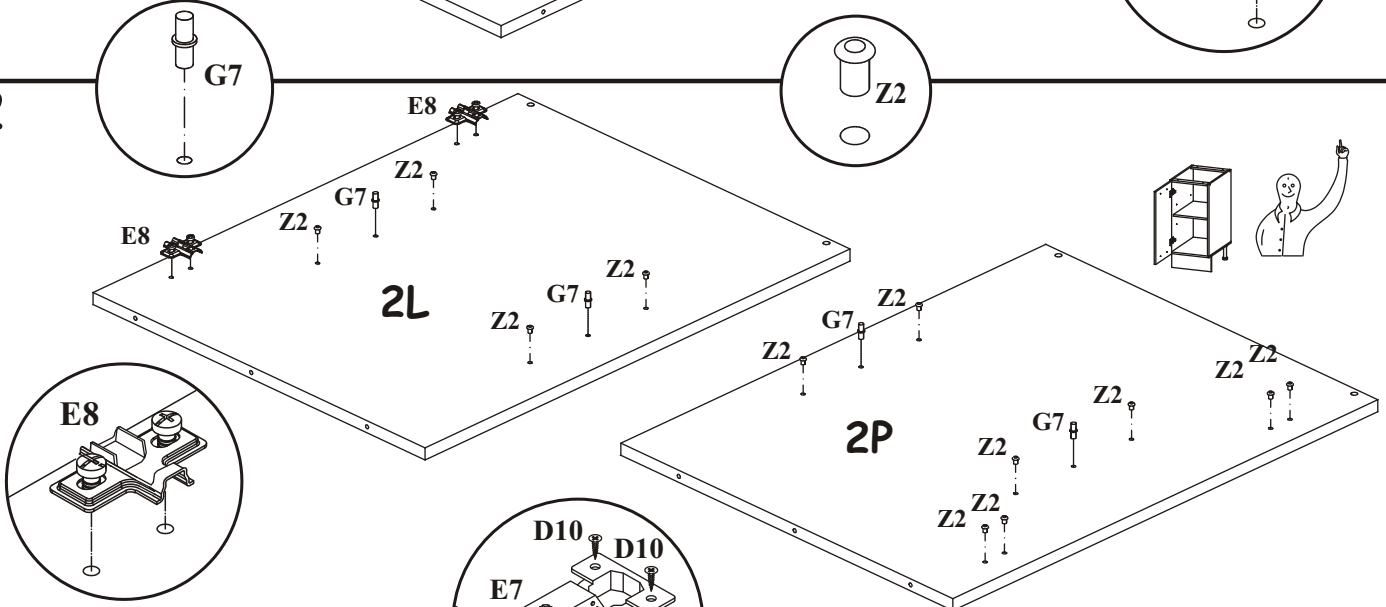

3

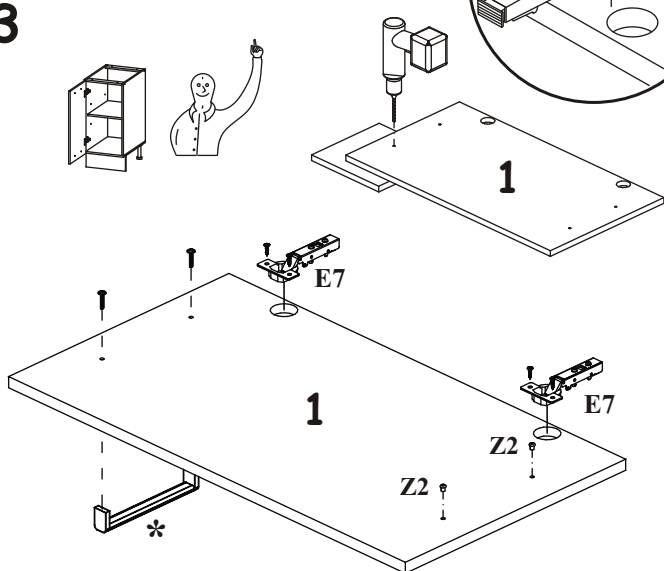

3

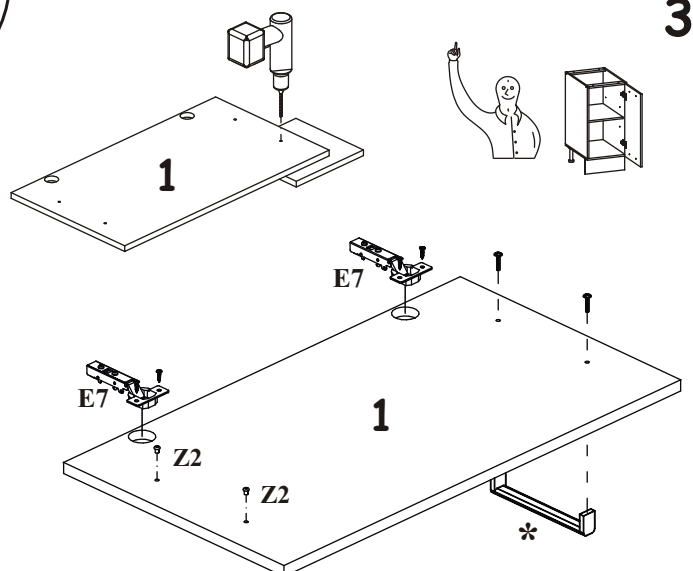

3

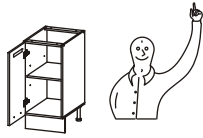

!!! KALA

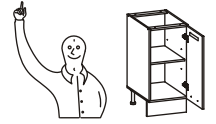
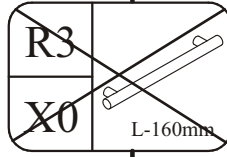
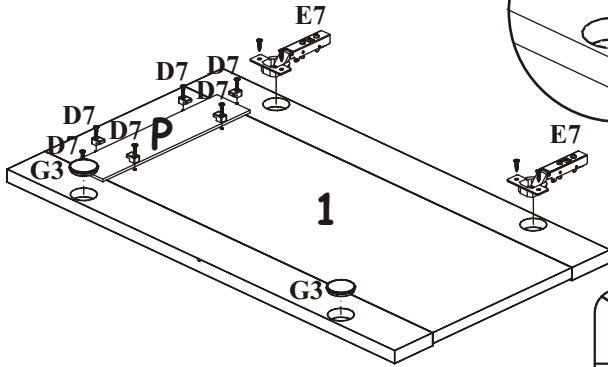

!!! KALA

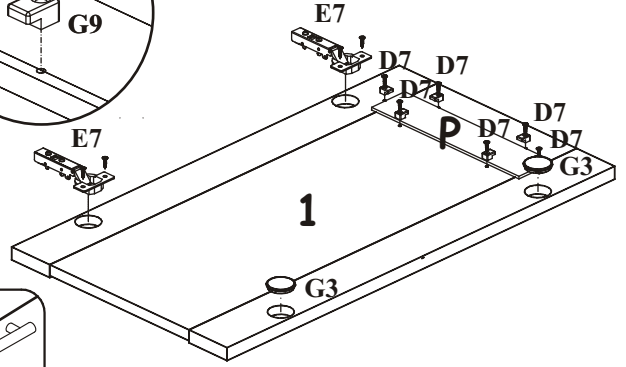

4

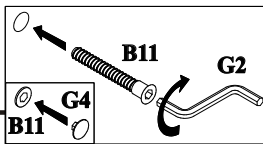
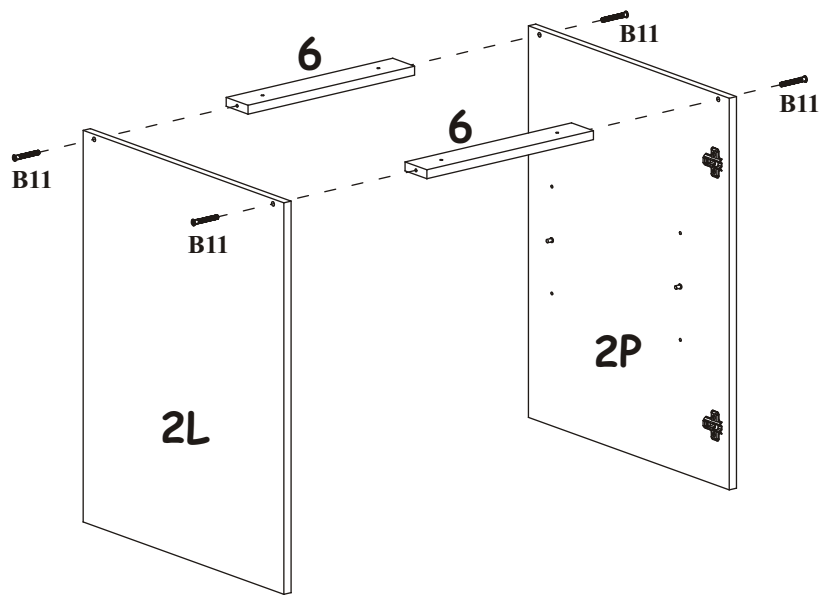
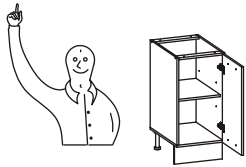

4

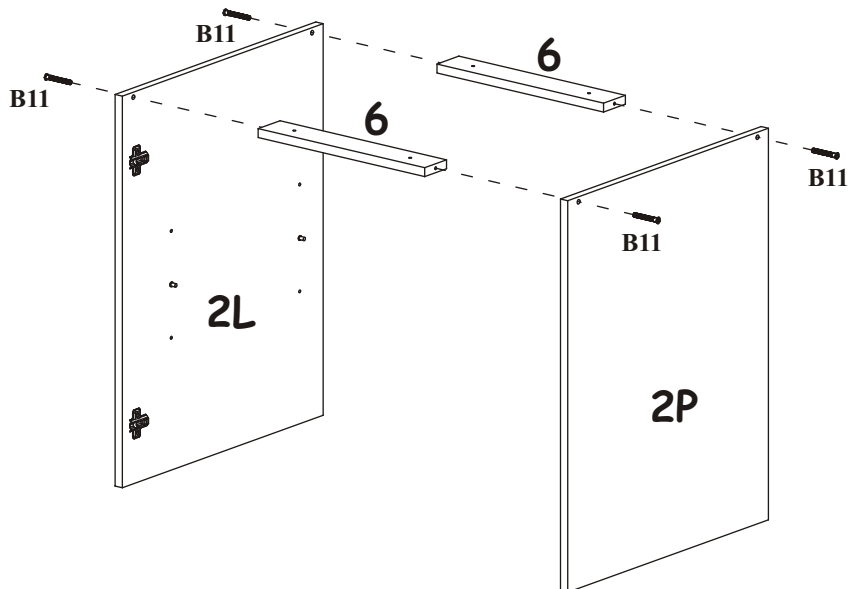
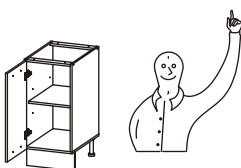

5

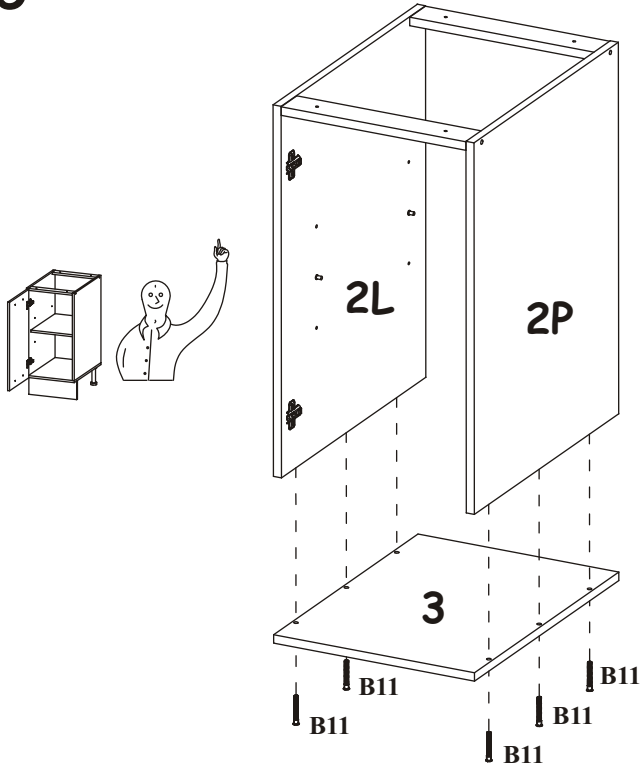

5

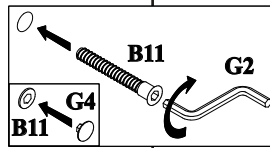
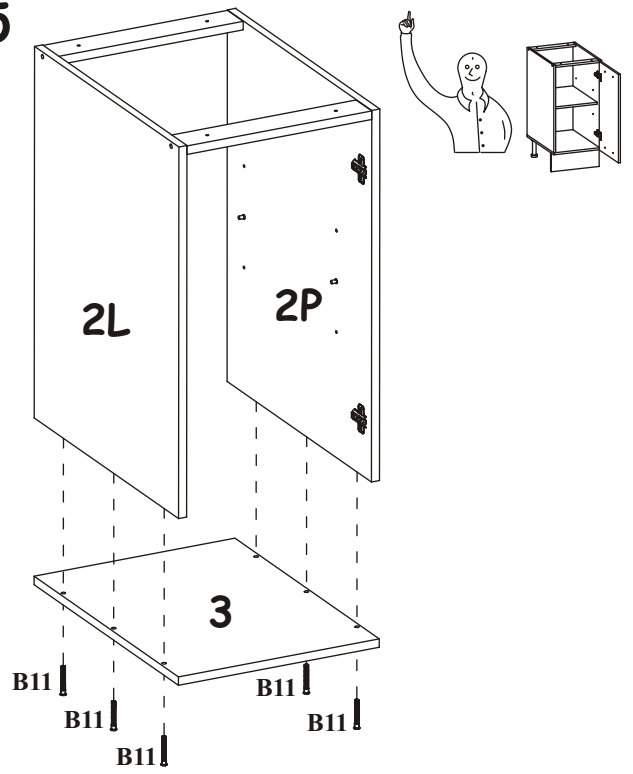

6

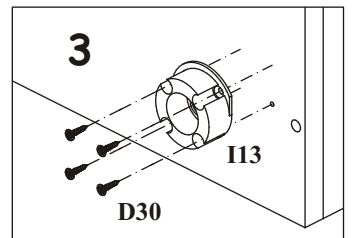
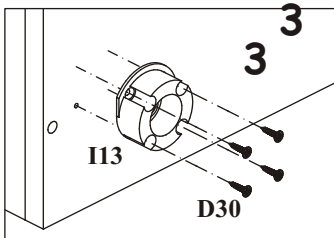
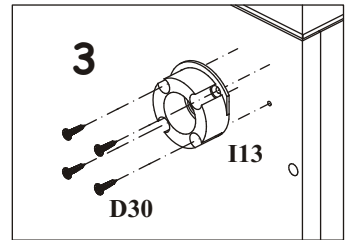
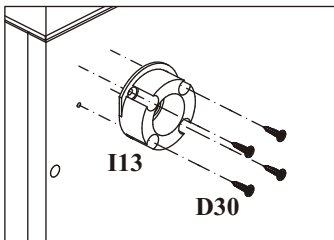
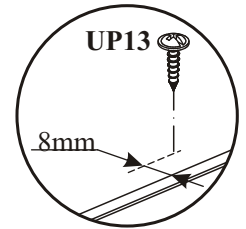
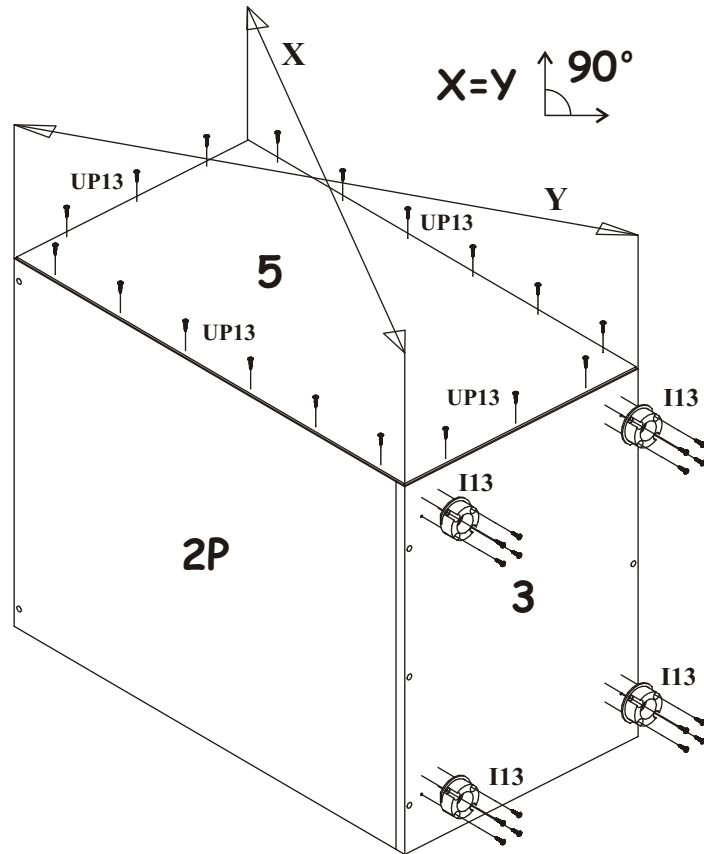

7

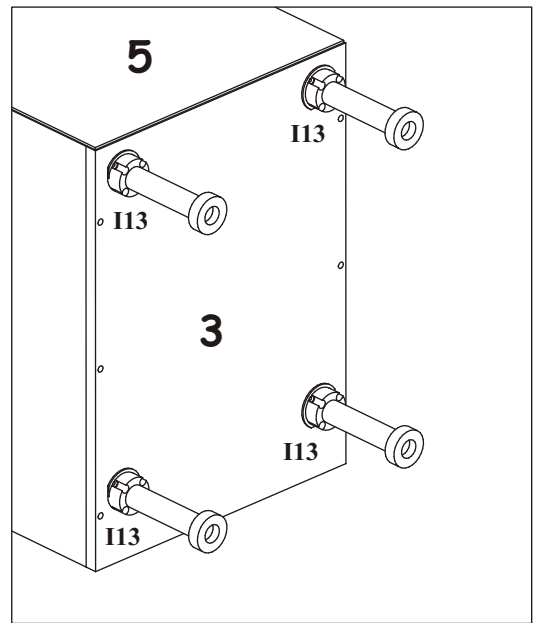
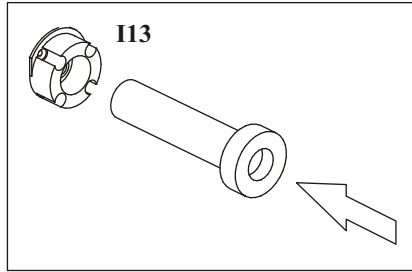

8

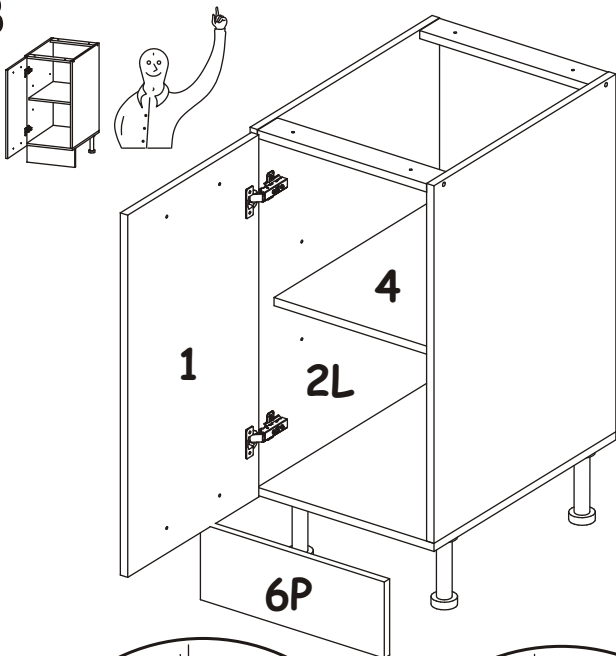

8

