

Outillage nécessaire

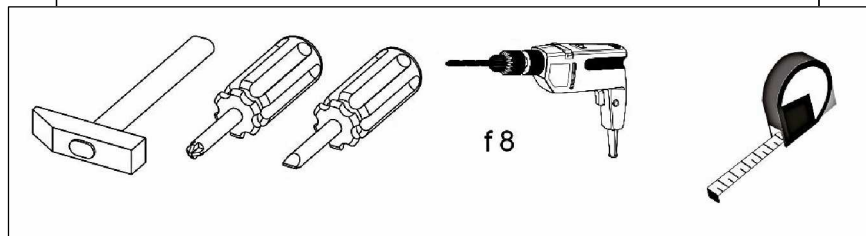
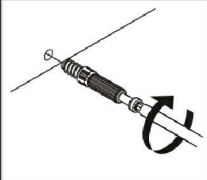
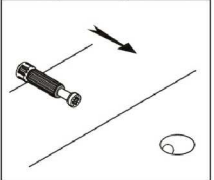
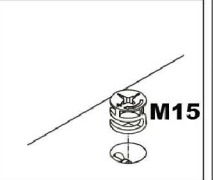
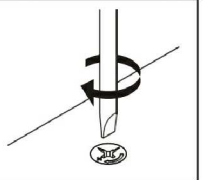

Principe d'assemblage par goujon/excentrique

<p>Step 1: Screw dowel into wooden element</p> 	<p>Step 2: Move element with mounted dowel to corresponding element</p> 	<p>Step 3: Place cam into hole with mounted dowel</p> 	<p>Step 4: Using screwdriver or Allen wrench twist cam clockwise.</p> 
---	--	--	---

ATTENTION! Avant l'installation, examiner soigneusement les étapes d'assemblage fournies par le fabricant.

Fig. 1-3

Préparation des éléments avant assemblage

1

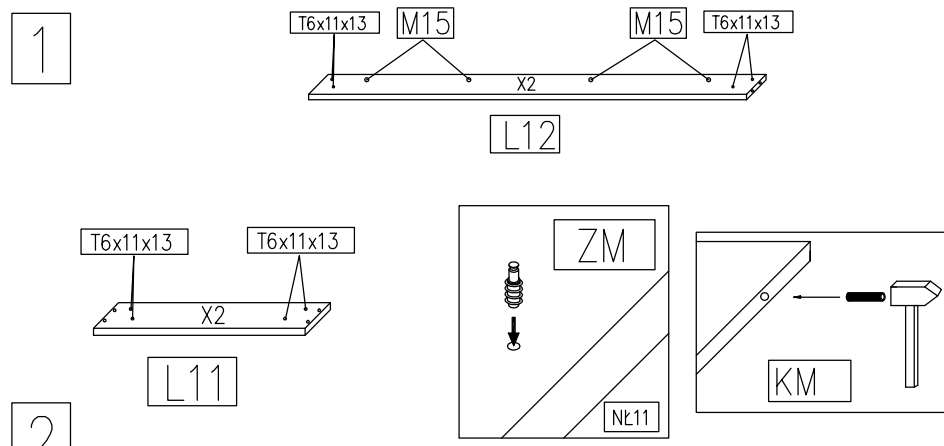

2

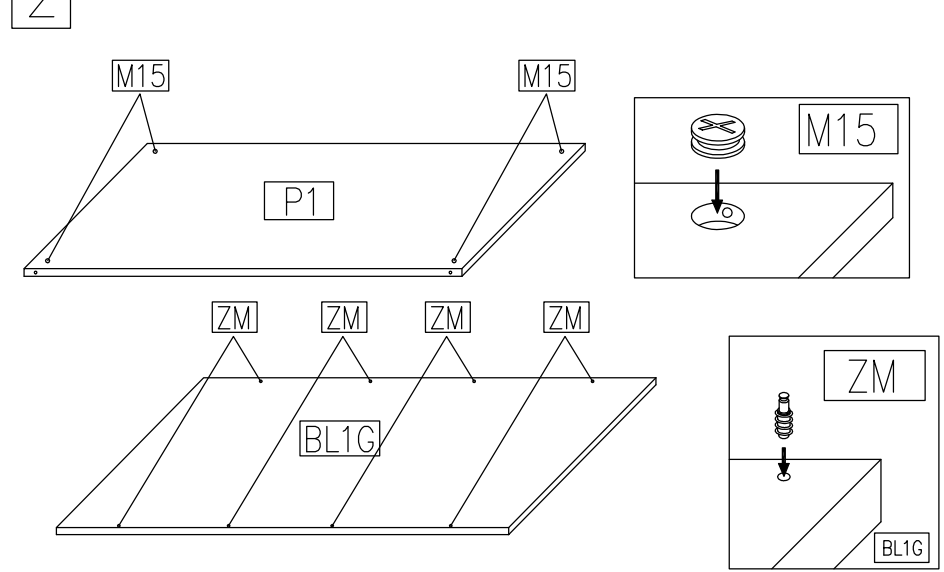
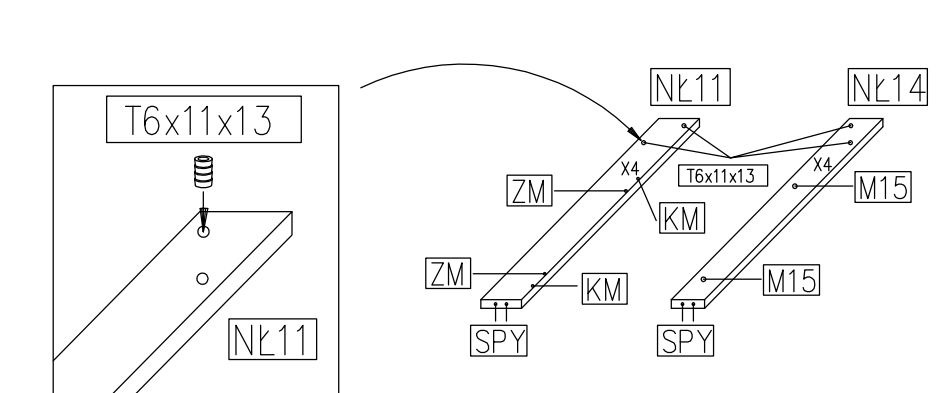
3

Fig. n°3

Assemblage des pieds NL11/NL12/NL13/NL14 (vis goujon/excentrique)

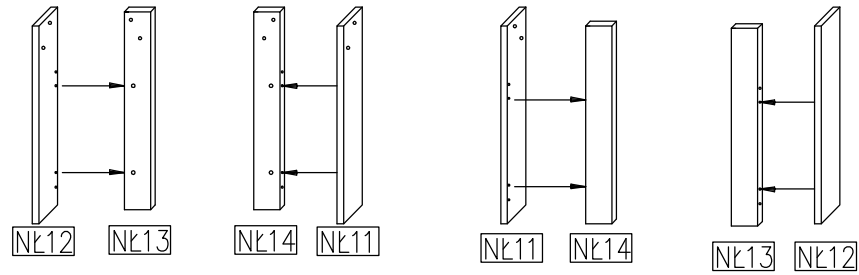

4

Fig. n°4

Assemblage des traverses de soutien du plateau supérieur par vis goujon/excentrique

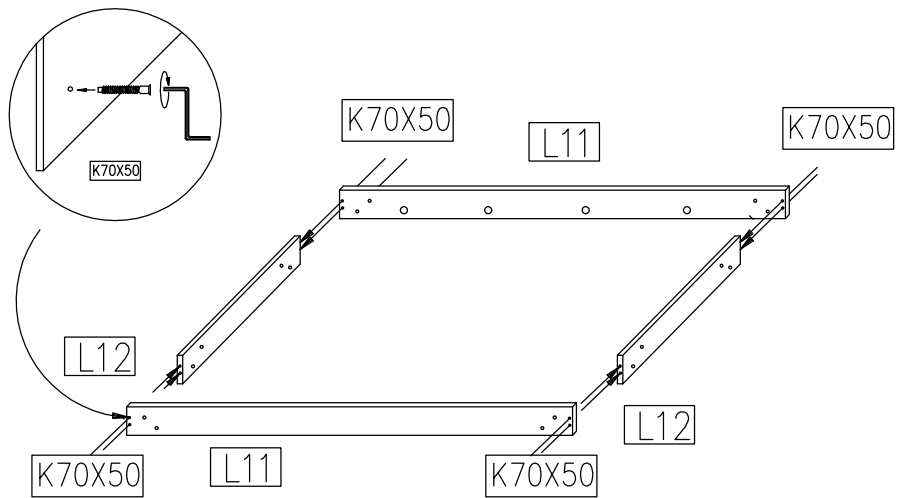

5

Fig. n°5

Assemblage du plateau inférieur et finaliser le montage.

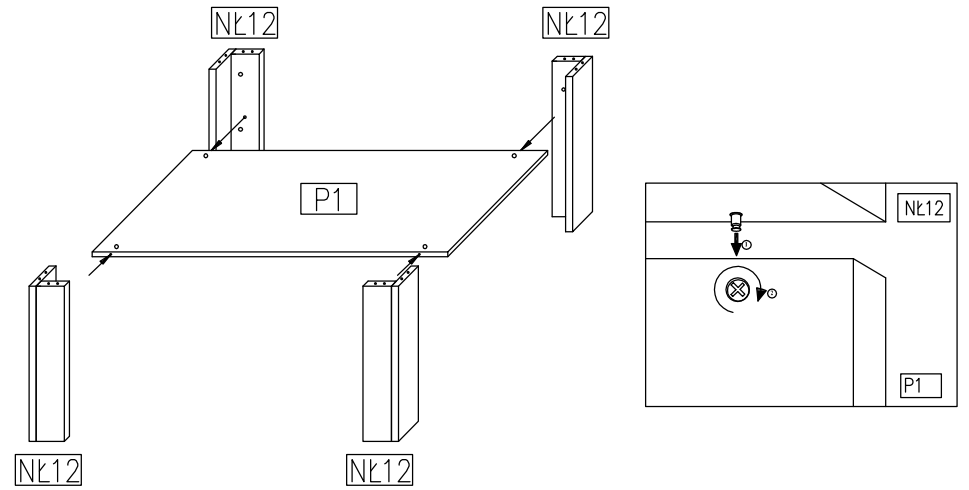

6

Fig. 6

Rassembler les pieds sur les traverses.

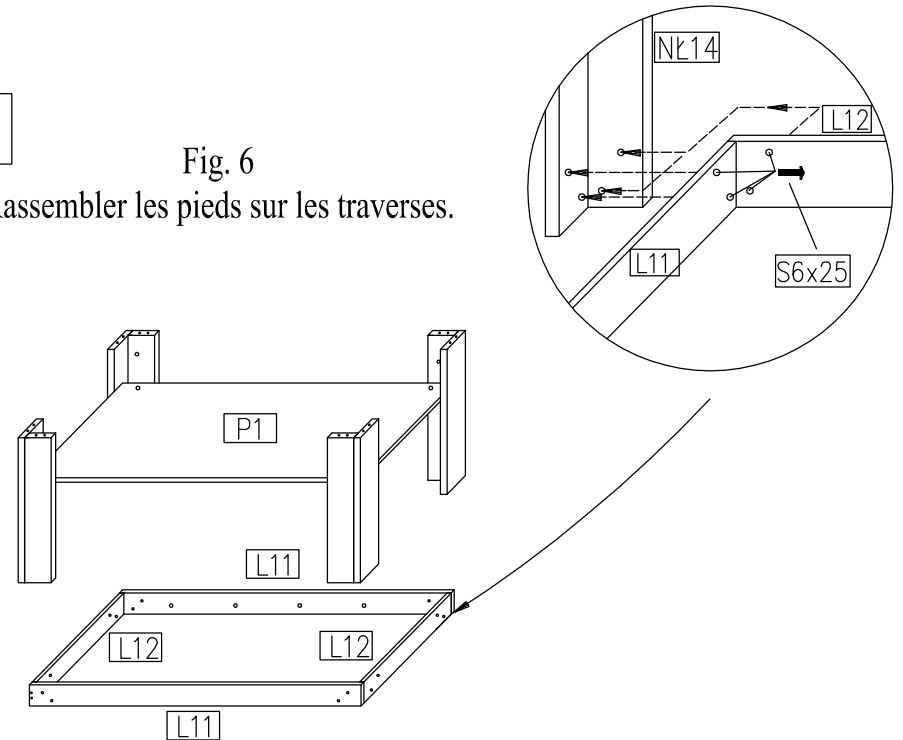

7

Fig. n°7
Monter l'ensemble sur le
plateau supérieur.

